

# SWRO Series 60 Hz

Seawater Desalination Machines  
45,000 ppm NaCl  
20-60 gpm (4.5-13.6 m<sup>3</sup>/hr)

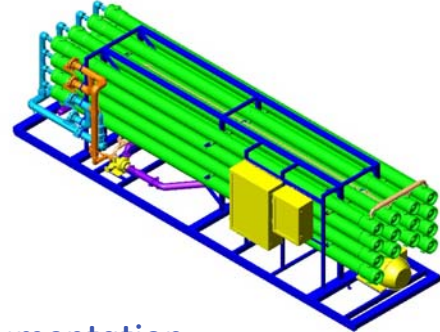

## Basic Features (BAS)

- GE Fanuc Quick Panel 6" 6-inch color display  
Primarily text operating screens  
Touchscreen controls
- GE Fanuc Micro VersaMax  
Communication: RS232/DH485  
Analog output: 6 points
- 4-20 mA instruments displayed on instrument center
- Variable frequency drive (VFD) for high pressure pump
- Stand alone master control enclosure, skid mounted local control enclosure with terminal strips

## Premium Features (PRE)

- GE Fanuc QuickPanel 12" 12-inch color display  
Text and pictorial operating screens  
Touchscreen controls
- GE Fanuc VersaMax  
Communication: RS232/DH485/Ethernet  
Analog output: 4 points
- 4-20 mA instruments on PanelView
- Primary and final pressure transmitters
- Variable frequency drive (VFD) for high pressure pump
- Automated valves and control for full permeate flush upon shut down
- Stand alone master control enclosure, skid mounted local control enclosure with remote I/O

## Instrumentation

Flow Meters	Permeate, concentrate
Conductivity	Permeate
pH	Feed
Pressure	Pre-filter, post-filter, primary, final, permeate, concentrate, pump discharge (PRE Feature = Primary, Final transmitter)
Pressure Switch	Feed, permeate, concentrate
Instrument center	Thornton 770 MAX

## Options Available

- Allen Bradley control system
- Multi-Media filters
- Clean-in-Place (CIP) units
- Chemical feed systems

## Documentation Included

- Operation and maintenance manual
- Control narrative
- Drawings: piping and instrumentation, electrical and general dimensional

## Operating Parameters

Recovery	35%
Design temp.	77°F (25°C)
Design Feed TDS.	45,000 ppm NaCl
Operating range	35 to 85°F (1.6 to 29.4°C)
Minimum inlet pressure	30 psi (2 Bar)



Visit us online at [www.gewater.com](http://www.gewater.com)  
©2004, General Electric Company.  
All rights reserved.

**Global Headquarters**  
Trevose, PA  
+1-215-355-3300

**Americas**  
Watertown, MA  
+1-617-926-2500

**Europe/Middle East/Africa**  
Heverlee, Belgium  
+32-16-40-20-00

**Asia/Pacific**  
Shanghai, China  
+86-21-5298-4573

\*Trademark of General Electric Company; may be registered in one or more countries.

PFE1007EN 0507

## Materials of Construction

High-pressure piping	Sch. 10, Duplex 2205 Stainless Steel
Low-pressure piping	Sch. 80, PVC
Frame	Painted carbon steel
Local Enclosure	FRP, NEMA 4X
Main Enclosure	Painted carbon steel, NEMA 4
VFD Enclosure	Painted carbon steel, NEMA 4
Clamps/fittings	Zinc-plated

## Membrane Elements and Housings

Style	Spiral-wound elements
Membrane type	TFC HR (Polyamide)
Element Area	400 ft <sup>2</sup>
Average membrane flux	8-10 GFD
Housing material	FRP, 80 Bar (1200 psi)
Housing closure type	Ring and plate style closure

## Cartridge Filtration

Housing material	GRP (glass reinforced plastic)
Cartridge filter	5-micron nominal, ROsave.Zs

## GE Infrastructure Water & Process Technologies SWRO Models

MODEL	SWRO-8	SWRO-16	SWRO-24
Permeate rate:	28.8k gpd 20 gpm (4.5 m <sup>3</sup> /hr)	57.6k gpd 40 gpm (9.0 m <sup>3</sup> /hr)	86.4k gpd 60 gpm (13.6 m <sup>3</sup> /hr)
Concentrate Rate:	37 gpm (8.4 m <sup>3</sup> /hr)	74 gpm (16.8 m <sup>3</sup> /hr)	111 gpm (25.2 m <sup>3</sup> /hr)
Feed Rate:	57 gpm (12.9 m <sup>3</sup> /hr)	114 gpm (25.8 m <sup>3</sup> /hr)	171 gpm (38.8 m <sup>3</sup> /hr)
Pumps and Motors			
Model:	MSS 1537	MSS 2030	MSS 3030
Manufacturer:	GE Osmonics/FEDCO®	GE Osmonics/FEDCO®	GE Osmonics/FEDCO®
Quantity:	1	1	1
Motor HP and type:	40Hp (29.9 kW) TEFC	75 Hp (55.9 kW) TEFC	100 Hp (74.6 kW) TEFC
Design Flow Rate:	60 gpm (13.6 m <sup>3</sup> /hr)	115 gpm (26.1 m <sup>3</sup> /hr)	170 gpm (38.6 m <sup>3</sup> /hr)
Design boost pressure:	690 psig (47.6 Bar)	660 psig (45.5 Bar)	620 psig (42.7 Bar)
Energy Recovery Booster			
Model:	HPB 20	HPB 30	HPB 40
Manufacturer:	GE Osmonics/FEDCO®	GE Osmonics/FEDCO®	GE Osmonics/FEDCO®
Quantity:	1	1	1
Design boost pressure:	315 psig (21.7 Bar)	340 psig (23.4 Bar)	380 psig (26.2 Bar)
Membrane Elements and Housings			
Membranes quantity:	8	16	24
Memb. housing style:	4 element long, 4 port	4 element long, 4 port	4 element long, 4 port
Banking Arrangement:	2, parallel	4, parallel	6, parallel
Cartridge Filtration			
Cartridge Filter:	ROZs05-40XK	ROZs05-40XK	ROZs05-40XK
Filter Length:	40" (102 cm)	40" (102 cm)	40" (102 cm)
Filter Quantity:	6 per change out	10 per change out	22 per change out
Installation and Utility Requirements			
Inlet:	2.0" flange	3.0" flange	3.0" flange
Permeate:	1.0" flange	1.5" flange	2.0" flange
Concentrate:	1.5" flange	2.0" flange	3.0" flange
Inlet Water Pressure:	30 psig, minimum	30 psig, minimum	30 psig, minimum
Air Pressure:	100 psig, oil-free	100 psig, oil-free	100 psig, oil-free
Drain to be Sized for:	57 gpm (12.9 m <sup>3</sup> /hr)	114 gpm (25.8 m <sup>3</sup> /hr)	171 gpm (38.8 m <sup>3</sup> /hr)
Power:	230/460 VAC, 3-phase, 60Hz	230/460 VAC, 3-phase, 60Hz	230/460 VAC, 3-phase, 60Hz
Control Circuit:	110 VAC, 1-phase, 60Hz	110 VAC, 1-phase, 60Hz	110 VAC, 1-phase, 60Hz
SWRO Skid			
Height:	88" (224 cm)	88" (193 cm)	88" (224 cm)
Width:	52" (132 cm)	52" (117 cm)	52" (132 cm)
Depth:	199" (506 cm)	199" (506 cm)	199" (506 cm)
Weight Estimate for Shipping Purposes:	3400 lb (1542 kg)	4000 lb (1814 kg)	4500 lb (2041 kg)